

BULK FUEL TANKS

Double Skinned



KEY FACTS

- 3,000 Litre Capacity
- Standard Tank Fittings
- 3" Fill Point
- 2" Fill Point
- Gauge
- Pressure Vacuum Vent
- Breather Vent
- Generator Fuel Supply & Return Fittings
- 2 x ¾", 2 x ½" (Quick Release Coupling, BSP)
- Forklift Pockets
- Connect Remote Telemetry
- Double Skinned

About

TransCube Deluxe, UN Approved, 110% bunded IBC fuel container c/w lockable pump cabinet & inspection hatch. Full crane & forklift galvanised protection frame. In addition to the standard TransCube benefits, the Dynamic range features: Tank fully enclosed in a fully galvanised framework protecting tank, paintwork, decals, base and forklift pockets. The galvanised base frame provides additional strength and protection to the tank base. Galvanised forklift pockets and lifting eyes help reduce damage during handling.



Tracking and
Telemetry



Remote Fuel
Management



24 Hour
Response Team



Disaster
Recovery

Dimensions & Weight

Height - 1.32M

Width - 1.55M

Length - 2.30M

Weight Empty: 1,072Kgs

Weight Full: 3,772Kgs

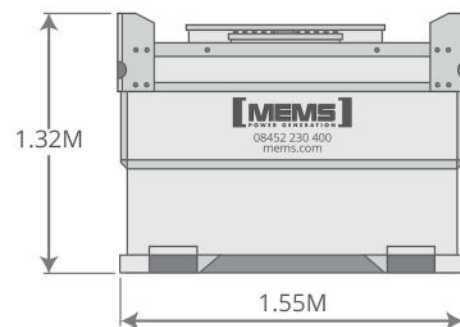
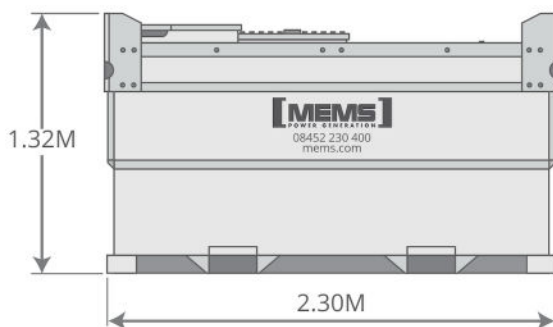

Specification Data

- Bund Material (thickness): S275 (3mm)
- Inner Tank Material (thickness): S275 (3mm)
- Design Approvals: ADR IBC Type 31A
- Capacity (brim full) - 2,990 Litres
- Capacity (brim full) - 658 Gallons
- Design Standards: Bunded to COP Regulations (PPG2)